



Four-Wire Solenoid Testing Procedures (White Connector)

- 1** Disconnect solenoid from harness at quick disconnect and check terminals for corrosion. Terminal plugs should be locked in place to the connector and should not come out. If terminals come out of the connector easily, it may not be making good contact with its mating terminal.

- 2** If terminals are free of corrosion and are firmly held in place in connector, jumper wires directly to the battery, as indicated in the diagram and following test procedures, to determine if the solenoid is functioning properly.
(see diagram A and B)
Test pull coil circuit first then proceed to the hold coil circuit.
When testing the pull coil, only make contact briefly (less than two seconds) as the pull coil draws up to 35 amps. The solenoid plunger should retract into the solenoid body. The plunger should return to its previous position when power is disconnected.

When testing the hold coil, contact can be made for a longer duration. Jumper the wires to the hold circuit as described in the diagram and manually move the plunger into the solenoid body. The hold coil only draws 0.7 amps and does not have the power to pull the plunger in. Plunger should stay in the solenoid until power is disconnected.

- 3** If the solenoid fails any of the above procedures or contacts are highly corroded; contact Corsa Performance for a replacement solenoid.

Three-Wire Solenoid Testing Procedure (Black Connector)

- 1** Disconnect solenoid from harness at quick disconnect and check terminals for corrosion. Terminal plugs should be locked in place to the connector and should not come out. If terminals come out to the connector easily, it may not be making good contact with its mating terminal.

- 2** If terminals are free of corrosion and are firmly held in place in connector, jumper wires directly to the battery, as indicated in the diagram and following test procedure, to determine if the solenoid is functioning properly.
(see diagram C)
Connect the Black wire first, followed by the white wire. When the red wire is connected the solenoid plunger should pull in and stay in until the either the red or black wire is disconnected. The white and black wires should stay cool even after a few seconds have passed. When disconnected the solenoid should return to its previous position.

- 3** If the solenoid fails the above procedure, the white or black wires gets hot, or the contacts are highly corroded; contact Corsa Performance for a replacement solenoid.

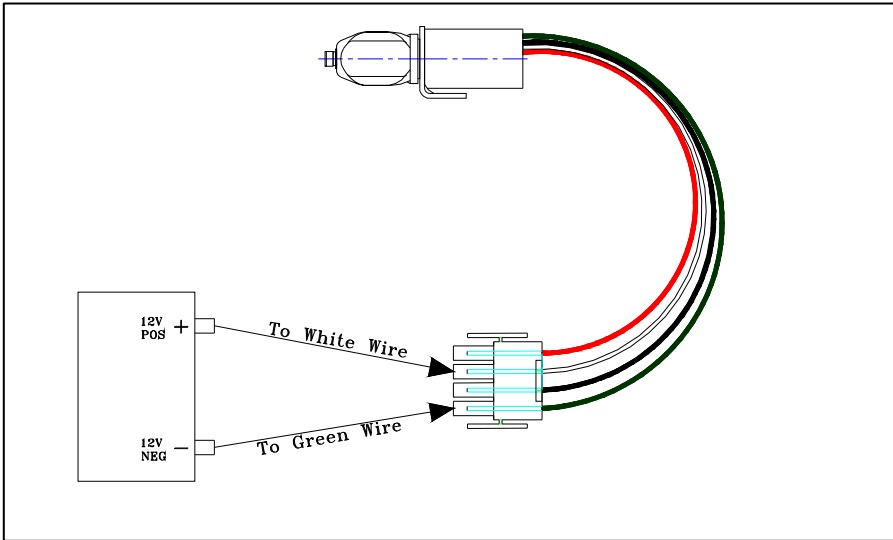

Diagram "A" Four-Wire Solenoid Pull Coil Test

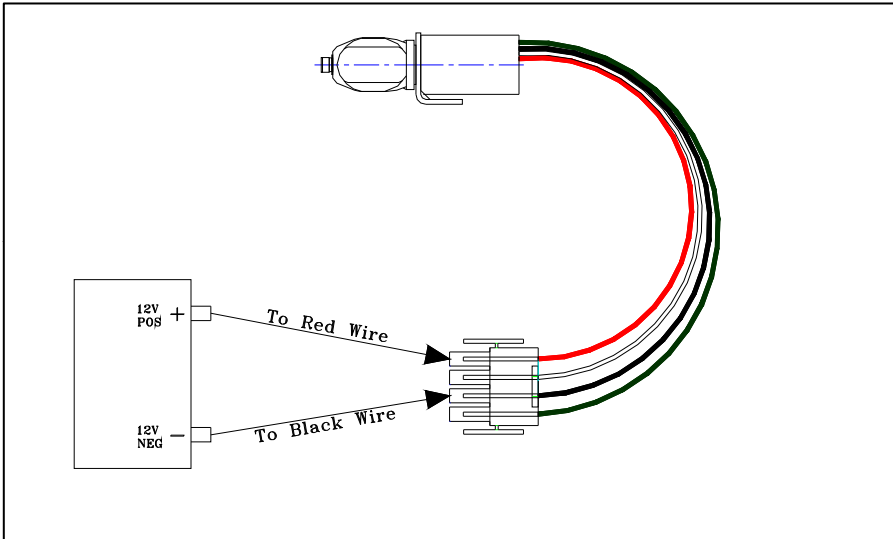

Diagram "B" Four-Wire Solenoid Hold Coil Test

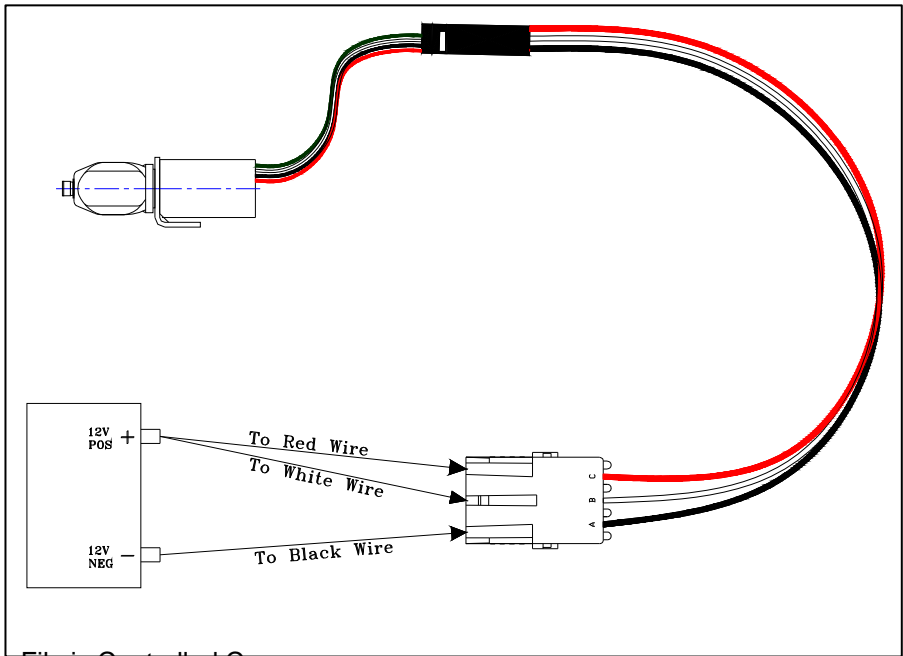

Diagram "C" Three-Wire Solenoid Test